

ELECTRONIC VALVE SPECIFICATIONS

SPECIFICATION CV7371-3

ISSUE NO.1 DATED 8.10.1962

AMENDMENT NO.1

Page 2

Primary Electrical Characteristics

Col:  $V_{CE}$  (sat) All devices delete 0.40V and insert 0.20V.  
Col:  $V_{BE}$  (sat) All devices delete 1.2V and insert 1.0V.

Page 4

Sub Group 3 Table 1

Collector Emitter Saturation Voltage  $V_{CE}$  (sat)

In max limit col: "Delete" 0.4V and "insert" 0.25V Also amend test to read "Collector Emitter Saturation Voltage 1"

P.T.O.

ELECTRONIC VALVE SPECIFICATIONS

SPECIFICATION CV7371-3

ISSUE 1. DATED 8th October 1962

Amendment No. 3

Page 2. Primary Electrical Characteristics

Col:  $I_{EBO}$  All devices delete 50 nA and insert 100 nA

Col:  $I_{EBO}$  Conditions. Against  $I_C$  insert "0"

Col:  $h_{FE}$  Conditions. Against  $V_{CB}$  All devices insert 6.0V

Page 4 Sub Group 2

Add the following new tests:-

				min.	max.	
Emitter Base Cut off Current	7.2.6	$V_{EB} = 5.0V$ $I_C = 0$	$I_{EBO}$	-	100	nA
Emitter Base Break-down Voltage	7.2.3	$I_C = 1 \mu A$	$BV_{EBO}$	6	-	V

Against 7.3.4 Delete  $V_{CE} = 6.0V$

Insert:  $V_{CB} = 6.0V$

P.T.O.

Base Emitter Saturation Voltage  $V_{BE}$  (sat)

In max limit col: "delete" 1.2V and "insert" 1.0V.

Static Forward Current Transfer Ratio

For CV7372. In max: col. "delete" 65 and insert 100

Page 8

SUB GROUP 1 TABLE 3

In col: Examination or Test Insert against 7.3.3. "Collector Emitter Saturation Voltage 2" Amend max limit for this test to read 0.2V instead of 0.35V.

In col: Examination or Test "Insert" against 7.3.1. "Collector Emitter Saturation Voltage 3" Amend 7.3.1. to read 7.3.3. Amend max. limit to read 0.075V.

SUB GROUP 2

Delete Vibration Variable Frequency completely.

September, 1963

Ministry of Aviation/RRE

Page 4 Sub Group 3

Against 7.3.4 Delete:  $V_{CE} = 6.0V$

Insert:  $V_{CB} = 6.0V$

Page 4 Sub Group 3

Against 7.3.4 Delete:  $V_{CE} = 6.0V$

Insert:  $V_{CB} = 6.0V$

Page 5 Sub Group 4

Against 7.3.4 Delete:  $V_{CE} = 6.0V$

Insert:  $V_{CB} = 6.0V$

December, 1964  
(310251)

Ministry of Aviation/RRE

ELECTRONIC VALVE SPECIFICATIONS  
SPECIFICATION CV7371 - 3  
ISSUE NO. 1 DATED 8.10.1962  
AMENDMENT NO. 2.

Page 7, Table 2. Group B Inspection (Contd.) Amend to read:-

Examination or Test	TEST CONDITIONS		AQL %	Insp Level	Sym-bol	Limits		Units
	K1007/ NATO REF.	Specific Conditions				Min.	Max.	
<u>SUB GROUP 8</u> Operating Life (1)	6.3	T <sub>amb</sub> at any single temperature between 25°C and 125°C with the corresponding P <sub>tot</sub> given by the derating curve on page 9. V <sub>ce</sub> max. for device duration 72 hrs. min.		III				
<u>Post Operating Life (1) Test End Point</u>								
Collector Base Cut-off current	7.2.5.1.	As in Group A	0.65		I <sub>CBO</sub>		55	NA
Static forward Current Transfer Ratio	7.3.4	As in Group A CV7371 CV7372 CV7373	0.65 0.65 0.65		HFE HFE HFE	32 70 32	88 180 88	

Amend Post Test End Points )  
For Sub-Groups 2. ) By deleting "and 8",  
3, 7 and 8 ) )

Page 8, Table 3. Group C Inspection. Add Sub-Group 3 as follows:-

Examination or Test	TEST CONDITIONS		AQL %	Insp Level	Sym-bol	Limits		Units
	K1007/ NATO REF	Specific Conditions				Min.	Max.	
<u>SUB GROUP 3</u> Operating Life (2)	6.3	As for Operating Life (1)	4.0	1A				
See Note 2	6.3	Duration 1000 Hrs. Min.						
<u>Post Operating Life (2) Test End Point</u>	4.5.2.1.1.1							
Collector Base Cut-off Current	7.2.5.1.	As in Group A			I <sub>CBO</sub>		55	NA
Static Forward Current Transfer Ratio	7.3.4.	As in Group A CV7371 CV7372 CV7373			HFE HFE HFE	32 70 32	88 180 88	

ADD TO NOTES

2. K1007 Section B Clause 4.5.3.3. will not apply, however the inspectorate will inform the qualification approval authority if and when the requirements of operation life (2) have not been met.

MILITARY SPECIFICATION

**CV 7371 - 3**

SEMICONDUCTOR DEVICE, TRANSISTOR

**Description:-** This specification covers the requirement for NPN Silicon Planar Epitaxial Transistors and is in accordance with Specification K1007 Issue 3, except where otherwise stated.

**Mechanical Dimensions and Outlines:-** K1007 Section B Drawing 10.3.2.4 and 10.4.2.4

**Connections:-** Collector connected to case. Lead 1, Emitter, Lead 2 Base, Lead 3 Collector.

**Absolute Maximum Ratings:-**

Device	Rating	V <sub>CB</sub>	V <sub>CE</sub>	V <sub>EB</sub>	I <sub>C</sub> mean	i <sub>C</sub>	P	T <sub>stg</sub>	T <sub>opr</sub>	Shock	Vib.
	Unit	V	V	V	mA	mA	mW	°C	°C	g	g
CV7371	Min.	-	-	-	-	-	-	-70	-70	-	-
	Max.	60	45	6	50	250	300	+175	+175	1500	20
CV7372	Min.	-	-	-	-	-	-	-70	-70	-	-
	Max.	60	45	6	50	250	300	+175	+175	1500	20
CV7373	Min.	-	-	-	-	-	-	-70	-70	-	-
	Max.	100	80	6	50	250	300	+175	+175	1500	20
NOTES							1,3			2	

- Notes
1. See Derating Curve Fig 1 Page 9.
  2. Duration 0.5ms.
  3. Averaged over 100ms period.
  4. Commercial equivalent ZT.83, 84 and 86.

(153057)

# CV7371-3

## Primary Electrical Characteristics:-

Characteristics		$I_{CBO}$	$I_{EBO}$	$V_{CE}$ (Sat)	$V_{BE}$ (Sat)	$h_{FE}$	$t_{on}$	$t_{off}$	$C_{ob}$	Noise Factor	$f_T$	
CV 7371	Unit	mA	nA	V	V		nS	nS	pF	dB	Mc/s	
	Min.	-	-	-	-	35	-	-	-	-	150	
	Nom.	-	-	-	-	-	100	175	-	6.0	-	
	Max.	50.0	50.0	0.40	1.2	85	140	500	8.0	10.0	500	
CV 7372	Min.	-	-	-	-	75	-	-	-	-	150	
	Nom.	-	-	-	-	-	100	175	-	6.0	-	
	Max.	50.0	50.0	0.40	1.2	170	140	500	8.0	10.0	500	
CV 7373	Min.	-	-	-	-	35	-	-	-	-	150	
	Nom.	-	-	-	-	-	100	175	-	6.0	-	
	Max.	50.0	50.0	0.40	1.2	85	140	500	8.0	10.0	500	
CONDITIONS	$T_{amb}$	$^{\circ}C$	25	25	25	25	25	25	25	25	25	
	$V_{CE}$	CV7371-e	V	45	-	-	-	-	-	6.0	-	-
		CV7373	V	80	-	-	-	-	-	6.0	-	-
	$V_{EB}$	V	-	6	-	-	-	-	-	-	-	
	$I_C$	mA	-	-	50	50	10	20	20	-	0.2	10
	$I_B$	mA	-	-	5.0	5.0	-	$(I_{B1} = I_{B2})$ 2		-	-	-
	$V_{CE}$		-	-	-	-	6.0	-	-	-	6.0	6.0
	$f$	kc/s	-	-	-	-	-	-	-	1000	1.0	-
$R_{source}$	Ohms	-	-	-	-	-	-	-	-	500	-	

Reliability Assurance Requirements:- Under discussion

Requirements

Marking The device shall be marked first with the CV number and then according to K1007, Issue 3, Section B, 1.3.4.

Quality Assurance Provisions

Destructive Tests The tests listed in Table 2, Group B inspection, Sub-Groups 2, 3 and 4 are considered destructive.

Preparation for delivery

Packaging The device shall be packed according to K1007, Issue 3, Section A, 1.2(c).

Group C Inspection This inspection shall be conducted on the initial lot, and thereafter every ninety days on every fifth lot, whichever occurs first.

Joint Services Catalogue Number

CV7371 = 5960-99-037-3204  
CV7372 = 5960-99-037-3205  
CV7373 = 5960-99-037-3206

TABLE 1. GROUP A INSPECTION

Examination or Test	K1007/NATO Ref.	TEST CONDITIONS		AQL %	Insp. Level	Sym-bol	LIMITS		Units
		SPECIFIC CONDITIONS					Min.	Max.	
<u>SUB-GROUP 1</u>									
5.1 Visual and Mechanical Inspection				0.65	I				
<u>SUB-GROUP 2</u>									
7.2.5.1 Collector Base Cut-off Current		$I_E = 0$ , CV7371-72 $V_{CB} = 4.5V$ CV7373 $V_{CB} = 80V$		0.65	II	$I_{CBO}$	-	50	nA
7.3.4 Static Forward Current Transfer ratio		$I_C = 10mA$ $V_{CE} = 6.0V$ CV7371 CV7372 CV7373				$h_{FE}$ $h_{FE}$ $h_{FE}$	35 75 35	85 170 85	
<u>SUB-GROUP 3</u>									
7.3.3 Collector Emitter Saturation Voltage		$I_C = 50mA$ $I_B = 5mA$				$V_{CE}$ (sat) $V_{BE}$ (sat)		0.40 1.2	V V
7.3.1 Base Emitter Saturation Voltage		$I_C = 50mA$ $I_B = 5mA$		2.5	I				
7.3.4 Static Forward Current Transfer Ratio		$I_C = 100\mu A$ CV7371, CV7373 CV7372				$h_{FE}$ $h_{FE}$	12 30	40 65	
Transition Frequency		$V_{CE} = 6V$ $I_C = 10mA$				$f_T$	150	500	Mc/s

TABLE 1. GROUP A INSPECTION (Contd.)

Examination or Test	TEST CONDITIONS		AQL %	Insp. Level	Sym- bol	LIMITS		Units
	K1007/NATO Ref.	SPECIFIC CONDITIONS				Min.	Max.	
<u>SUB-GROUP 4</u>			6.5	IA				
Collector Base Cut-off Current	7.2.5.1	$T_{amb} = 100^{\circ}C \pm 2^{\circ}C$ $V_{CB} = 20V$ $I_E = 0$			$I_{CBO}$	-	1.0	$\mu A$
Emitter Base Cut-off Current	7.2.6	$T_{amb} = 100^{\circ}C \pm 2^{\circ}C$ $V_{EB} = 6V$ $I_C = 0$ See Page 9 $I_C = 20mA$			$I_{EBO}$	-	1.0	$\mu A$
Turn-on Time		See Page 9 $I_B = 2mA$			$t_{on}$	-	140	nS
Turn-off Time					$t_{off}$	-	500	nS
Collector Base Capacitance	7.4.8	$V_{CB} = 6V$ $I_E = 0, f = 1Mc/s$			$C_{ob}$	-	8.0	pF
Static Forward Current Transfer Ratio	7.3.4	$T_{amb} = -55^{\circ}C$ $V_{CE} = 6.0$ $I_C = 10mA$			$h_{FE}$ $h_{FE}$ $h_{FE}$	17.0 40.0 17.0		



CV7371-3

TABLE 2. GROUP B INSPECTION  
(See Page 3, Quality Assurance Provisions, Destructive Tests)

Examination or Test	K1007/NATO Ref.	TEST CONDITIONS		AQL %	Insp. Level	Sym- bol	LIMITS		Units
		SPECIFIC CONDITIONS					Min.	Max.	
<u>SUB-GROUP 1</u>				6.5	1C				
Physical Dimensions	5.1								
<u>SUB-GROUP 2</u>				4.0	1A				
Solderability	5.13								
Temperature Cycling	5.5		-55°C to +150°C						
Thermal Shock	5.6.1		+0°C to 0°C + 5°C						
Moisture Resistance	5.3.1		100°C -5°C - 0°C						
<u>SUB-GROUP 3</u>				4.0	1 (Note 1)				
Vibration Fatigue	5.15.1		Non-operating						
<u>SUB-GROUP 4</u>				6.5	1A				
Lead Fatigue	5.10.1		3 Cycles						
<u>SUB-GROUP 5</u>									
Omitted									
<u>SUB-GROUP 6</u>									
Omitted									

TABLE 2. GROUP B INSPECTION (Contd.)

Examination or Test	TEST CONDITIONS		AQL %	Insp. Level	Sym- bol	LIMITS		Units
	K1007/NATO Ref.	SPECIFIC CONDITIONS				Min.	Max.	
<u>SUB-GROUP 7</u>			4.0	1 (Note 1)				
Storage Life (1)	6.2.1	T <sub>stg</sub> 175°C Duration 1000hours						
Storage Life (2)		T <sub>stg</sub> -55°C Duration 1000hours						
<u>SUB-GROUP 8</u>			4.0	1A				
Operating Life	6.3	T <sub>amb</sub> at any single temperature between 25°C and 125°C with the corresponding P <sub>tot</sub> given by the derating curve on Page 9 . V <sub>CE</sub> max for device. Duration 1000 hours.						
<u>Post Test End Points for Sub-Groups 2, 3, 7 and 8</u>								
Collector Base Cut -off Current	7.2.5.1	As in GROUP A			I <sub>CBO</sub>		55	nA
Static forward current transfer ratio	7.3.4	As in Group A			h <sub>FE</sub> h <sub>FE</sub> h <sub>FE</sub>		32 70 32	88 180 88

CV7371-3

TABLE 3. GROUP C INSPECTION (See GROUP C Inspection. Quality Assurance Provisions Page 3)

Examination or Test	K1007/NATO Ref.	TEST CONDITIONS	AQL %	Insp. Level	Sym- bol	LIMITS		Units
						Min.	Max.	
<u>SUB-GROUP 1</u>	7.3.3	$T_{amb} = -55^{\circ}C, I_C = 50mA, I_B = 5mA,$ $T_{amb} = +25^{\circ}C, I_C = 10mA, I_B = 2mA,$	1.0	II	$V_{CE}$ (sat) $V_{CE}$ (sat)		.35	V
	7.3.1.						.15	V
<u>SUB-GROUP 2</u>	5.17	Non-operating	6.5	IA				
	5.16.1	Non-operating	6.5	IA				

NOTES

1. The maximum sample size shall be 125.

FIG 1.

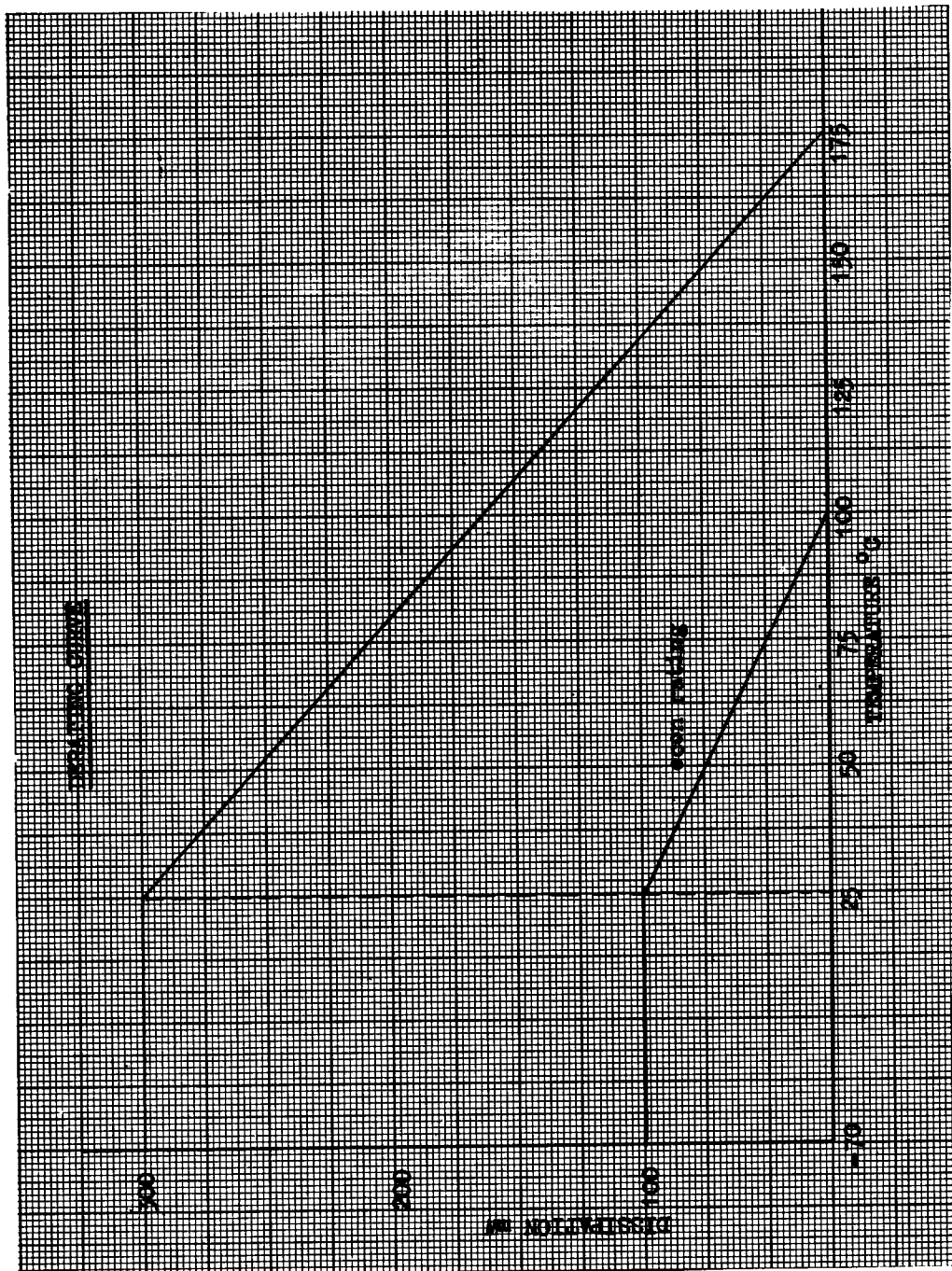

FIG 2.

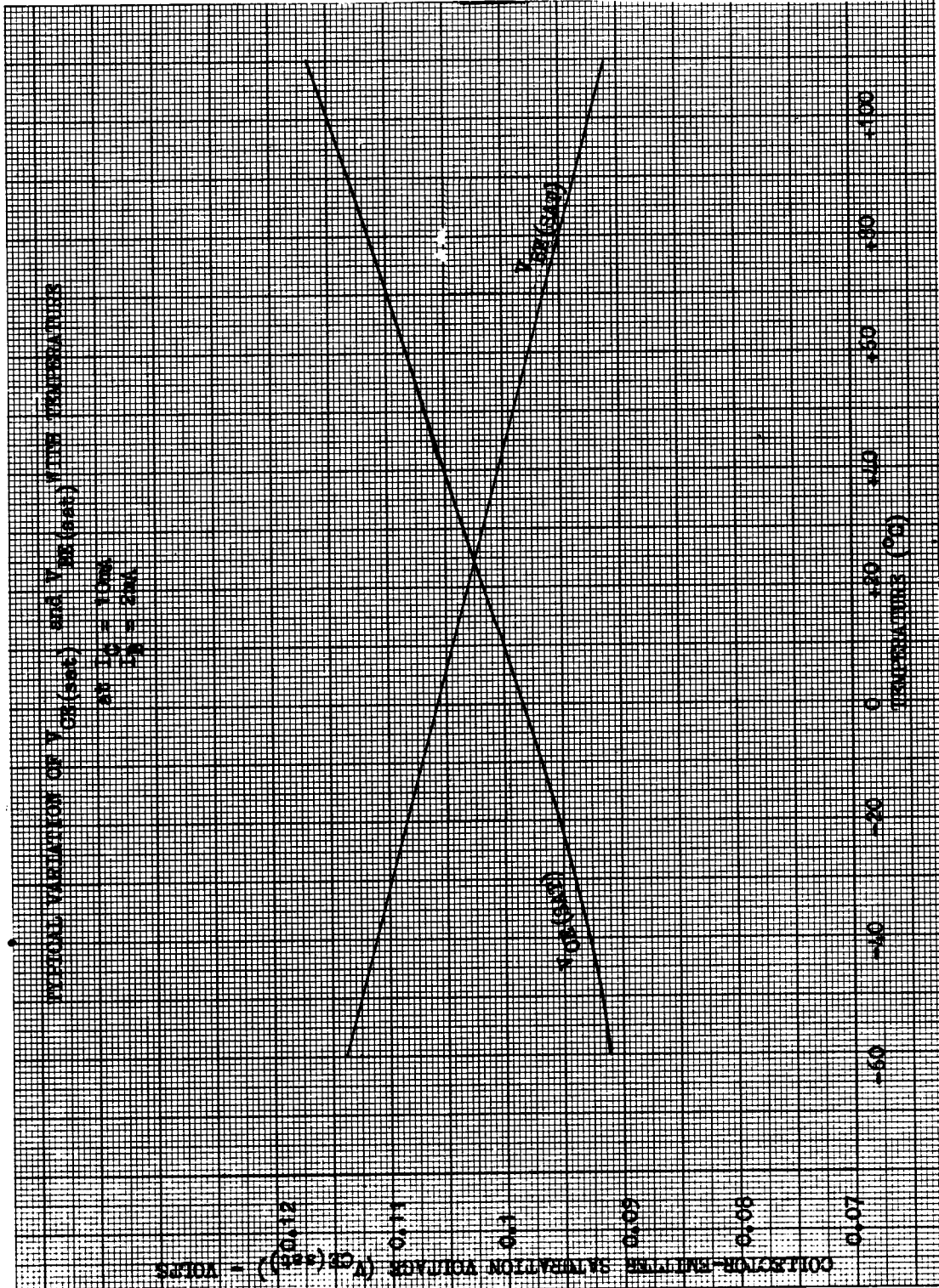

FIG 3.

TYPICAL VARIATION OF DC GAIN WITH TEMPERATURE  
(Pulsed Measurement)

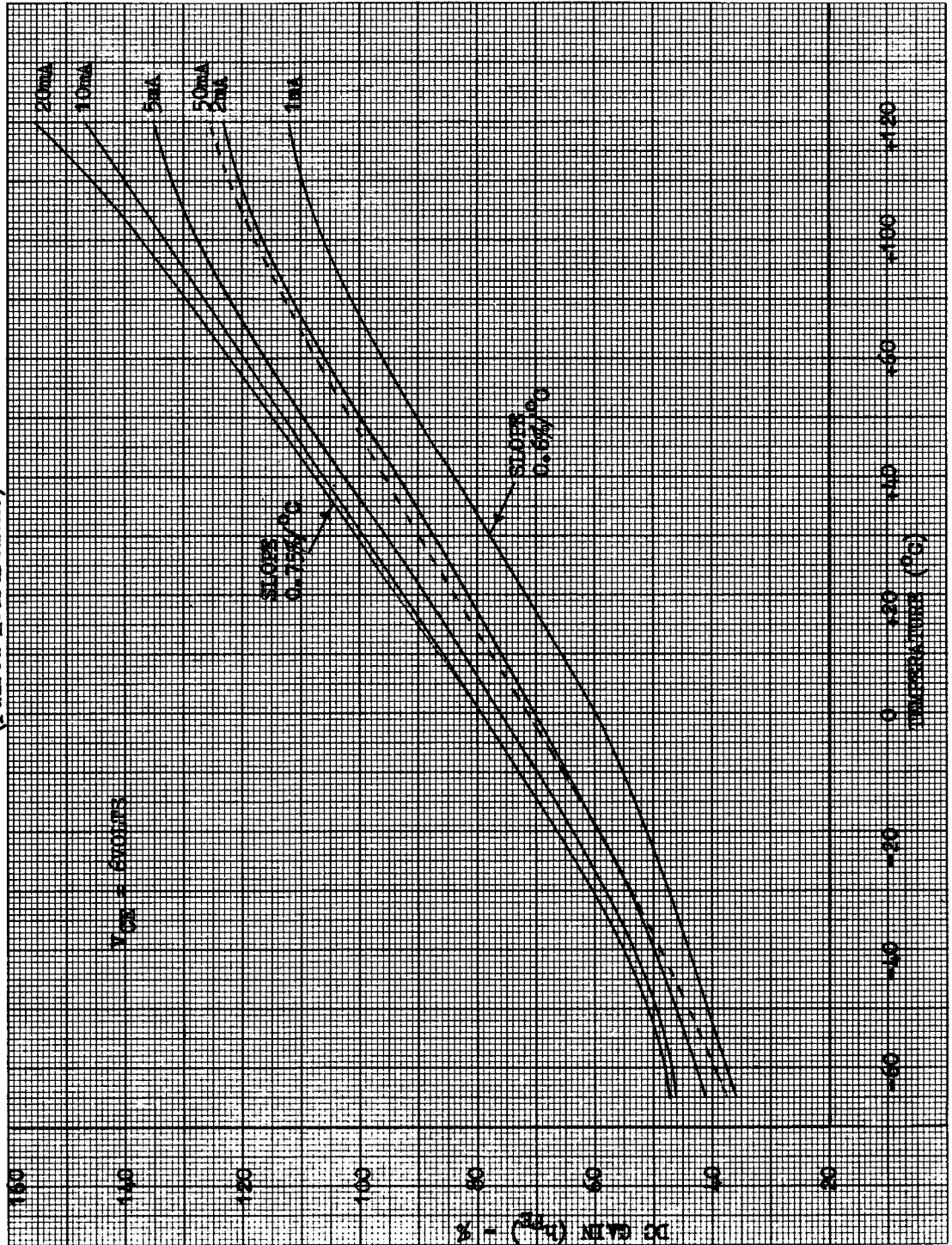

FIG 4.

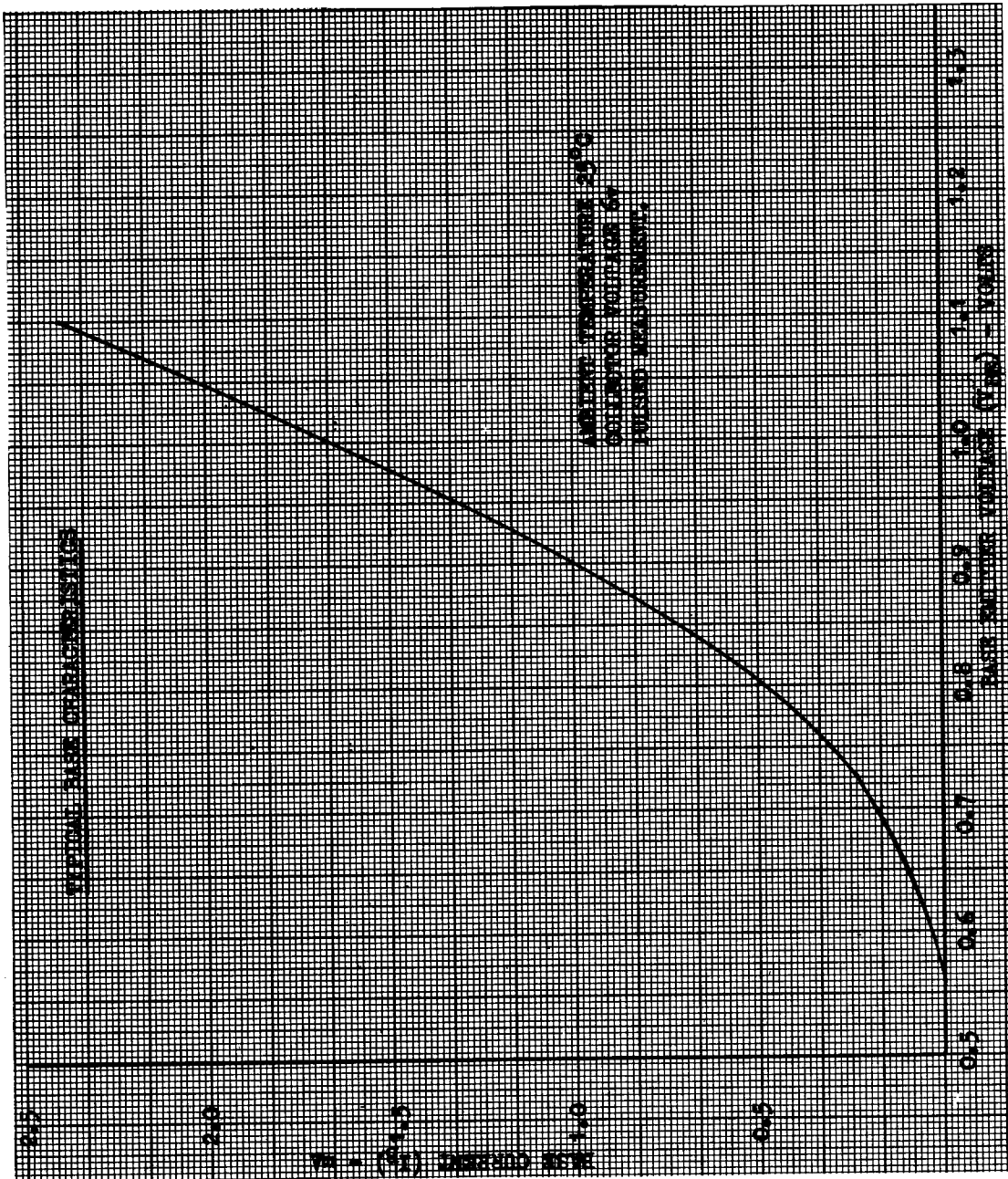

FIG 5.

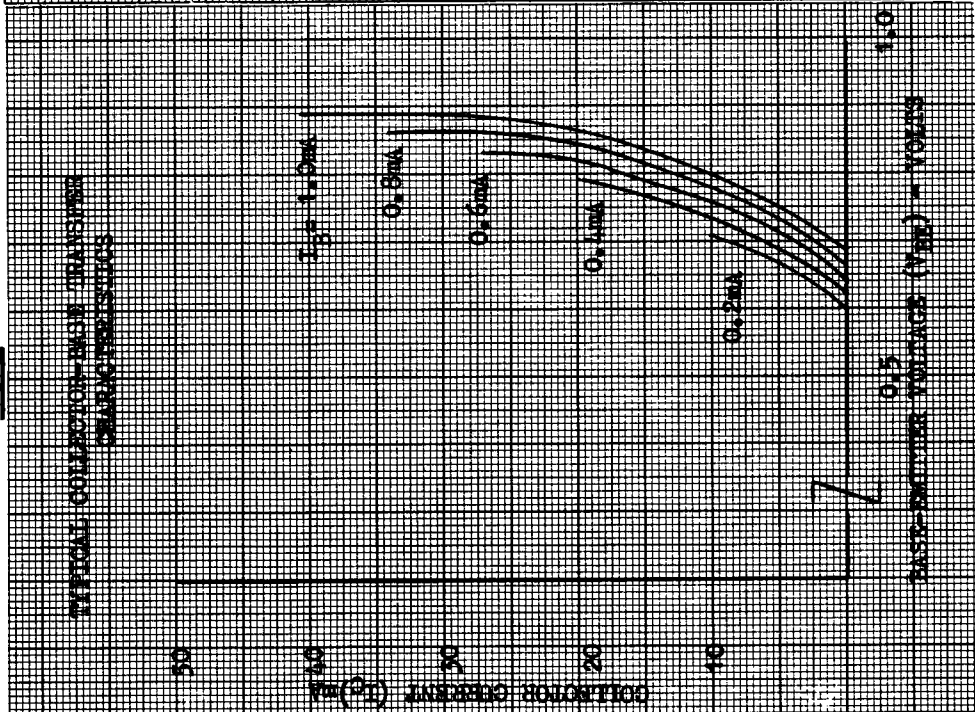
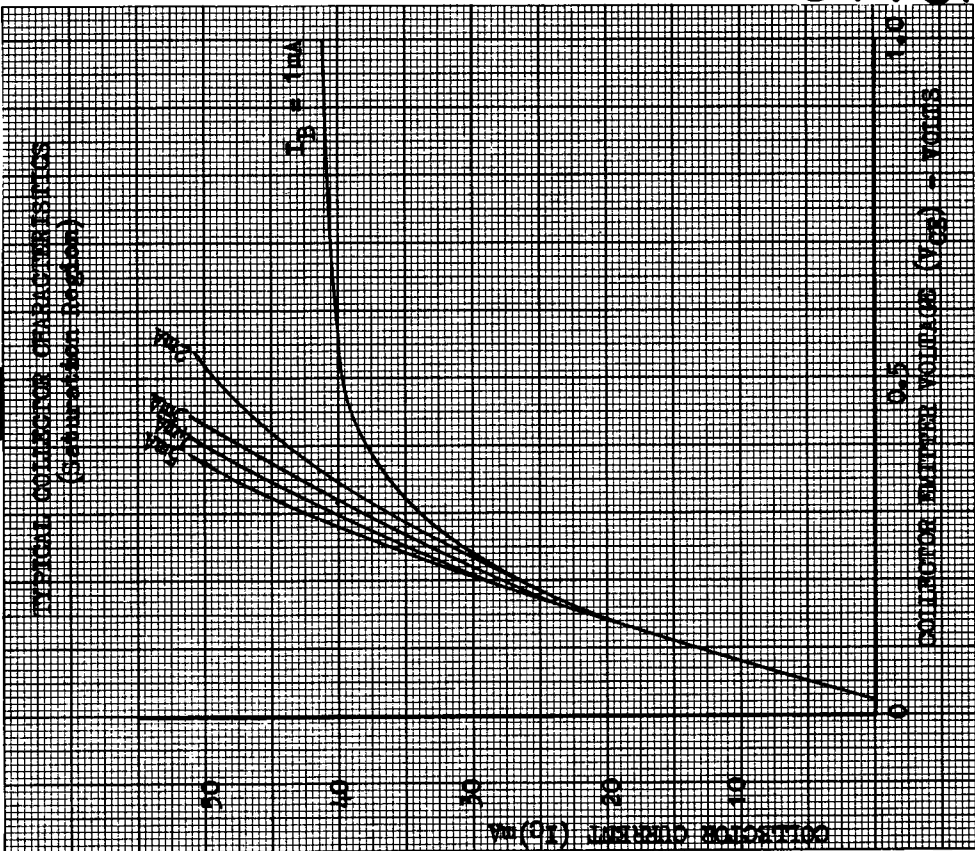
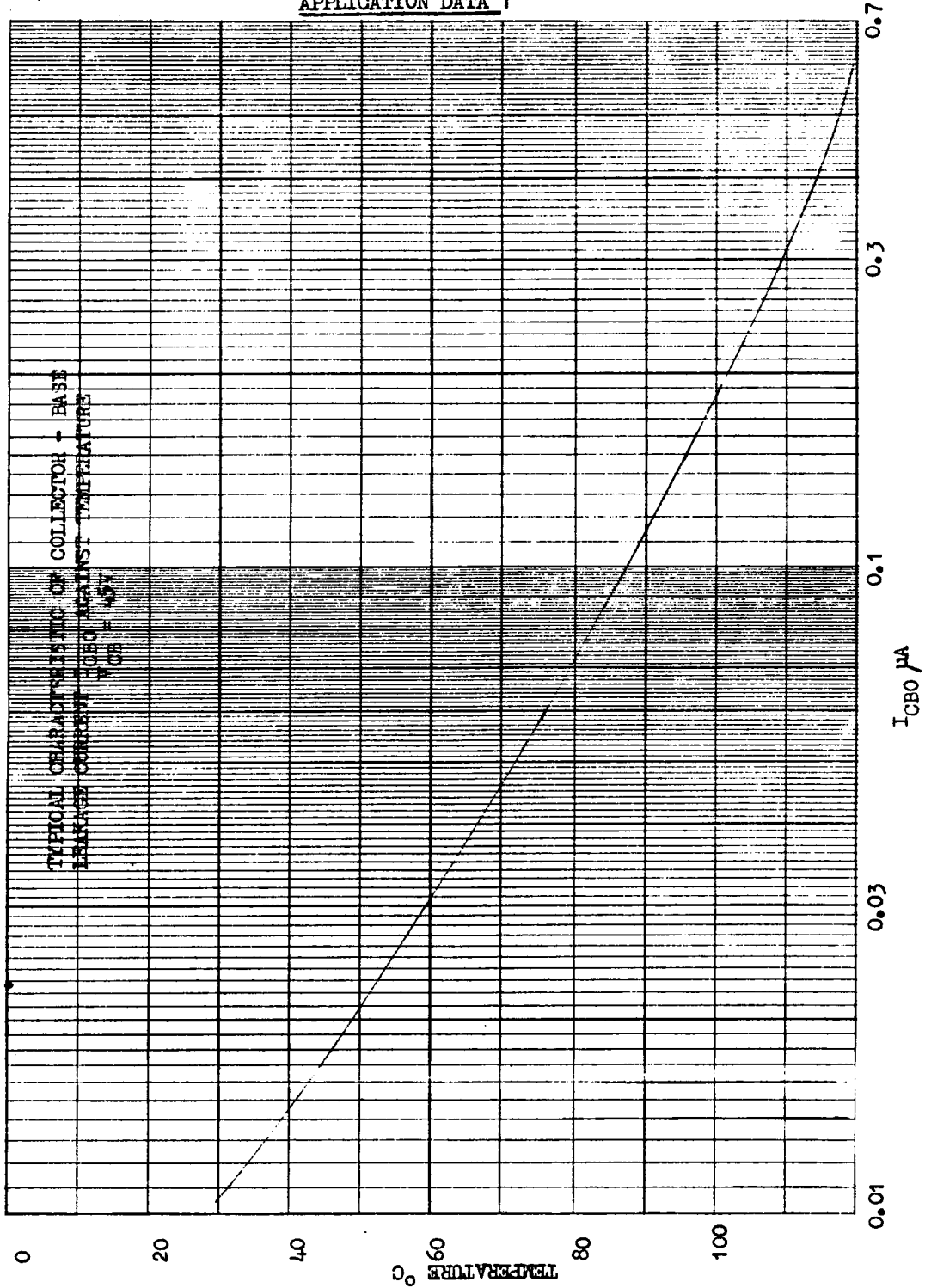

FIG 6.





APPLICATION DATA 1



TYPICAL VARIATION OF D.C. CURRENT GAIN.

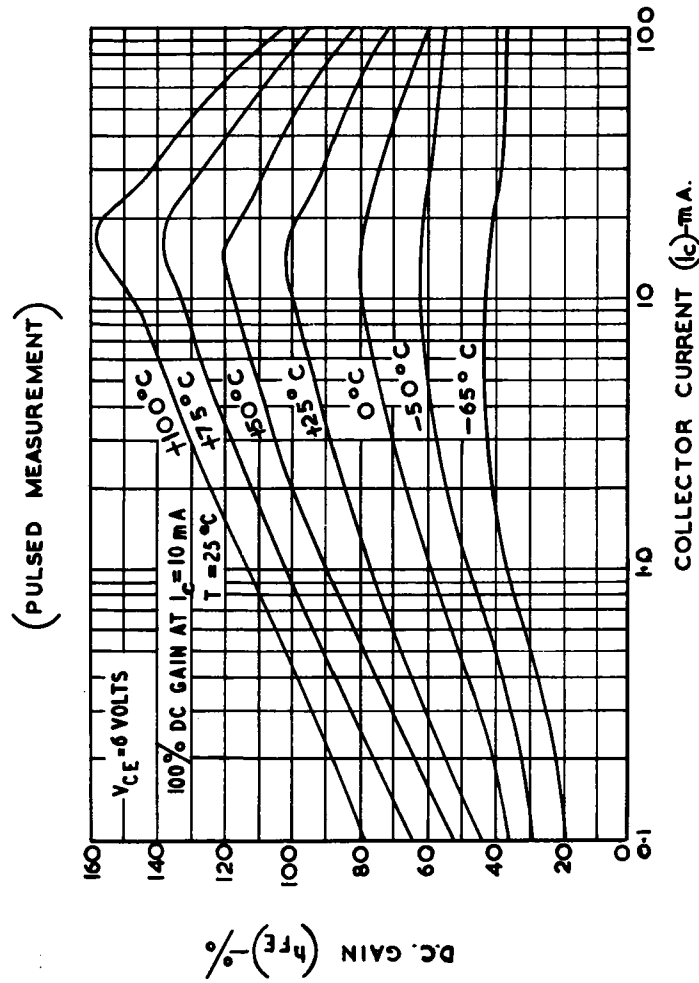

### TYPICAL SWITCHING PERFORMANCE

TEST CIRCUIT

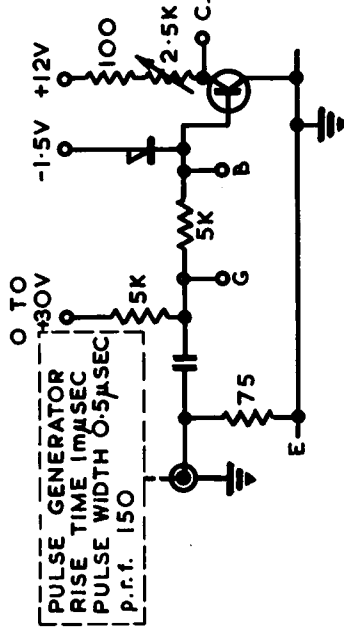

WAVEFORM

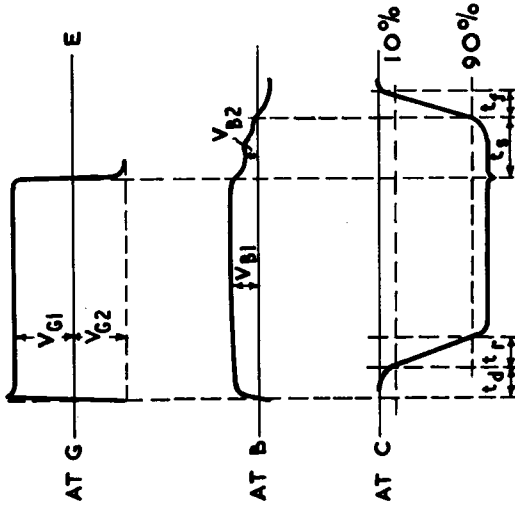

TEST CONDITIONS

$$I_c = 20 \text{ mA}$$

$$I_{B1} = I_{B2} = 2 \text{ mA}$$

$$I_{B1} = \frac{V_{G1} - V_{B1}}{R}$$

$$I_{B2} = \frac{V_{G2} - V_{B2}}{R}$$

TYPICALLY:

$$t_{ON} = t_d + t_r = 100 \mu\text{ SECS}$$

$$t_{OFF} = t_s + t_f = 175 \mu\text{ SECS}$$

NOTE: C.R.O. BANDWIDTH  $\geq 100 \text{ Mc/s}$